

SKMS

SK MANAGEMENT SYSTEM

SK

- ◆
- ◆ SKMS
- ◆ SKMS

- ◆
 -
 - 가
 -

- ◆
 - SK Management System
 - SUPEX /
 -
 - SUPEX

- ◆
 -
 -
 -
 -
 - .
 - MARKETING
 -
 -
 -
 -
 - PR
 -

-
-
- COORDINATION
- COMMUNICATION
- SK-MANSHIP

- ◆ SUPEX
 - Super Excellent (SUPEX)
 - 5
 - MPR/S/T
 - Can Meeting
 - SUPEX

- ◆ SKMS

SKMS

SKMS

SK

가

가

가

. , SKMS

SK SKMS

2000

Globalization

SKMS

1979

80

SKMS

90

SUPEX

SKMS

50

가

SK가

SKMS

50

가

가

가

2000

SKMS

SUPEX

SUPEX
Process

SKMS가

가

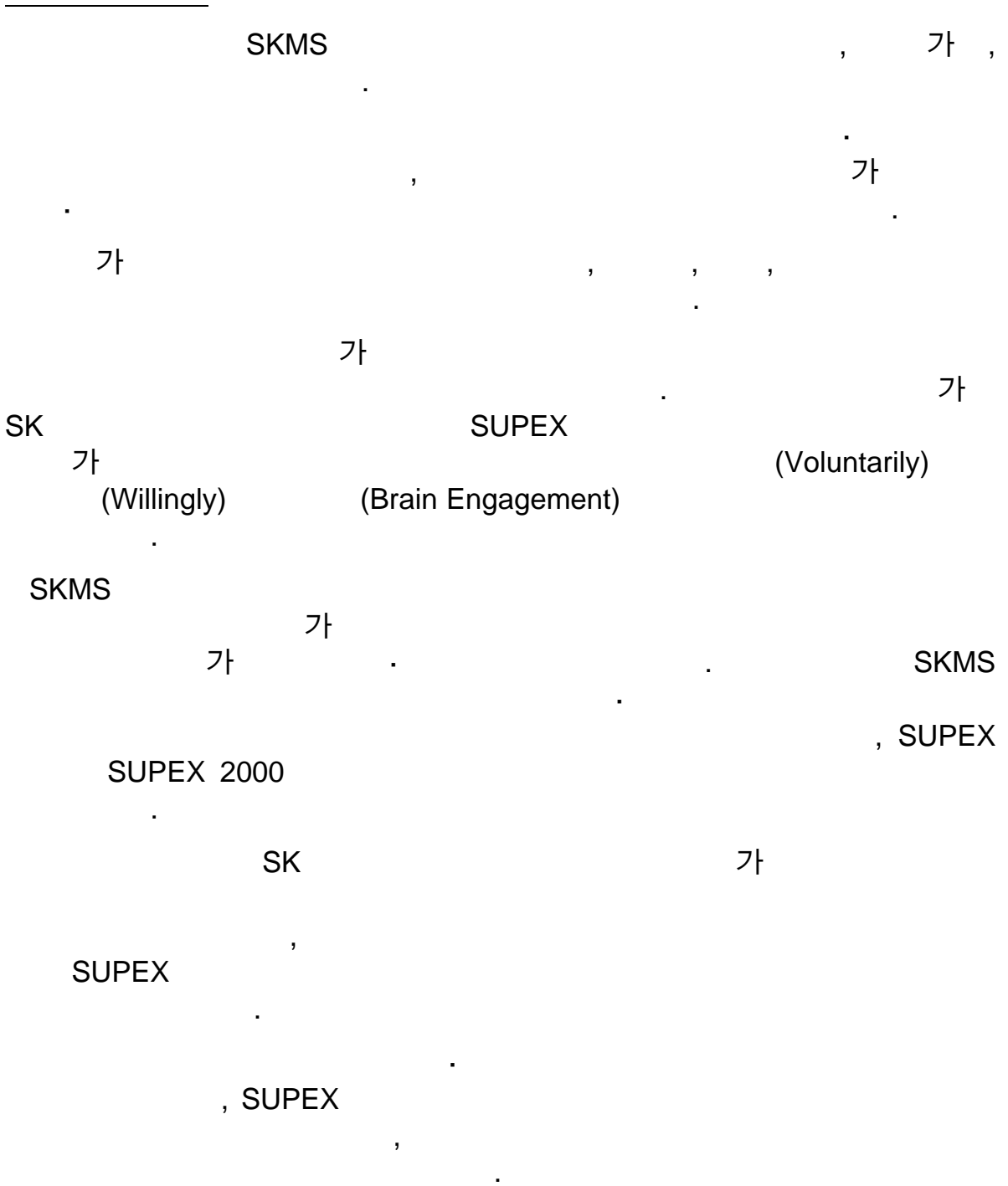

SKMS

SKMS SK

SKMS

SK

SK

SKMS

SK Brand

SK

가

가

, SK

가

SKMS

SKMS

2004. 10.

가 .

가

1975

(’79. 3. 15. ~ 3. 18.)

(Sunkyong Management System

SKMS)

(Static)

(Dynamic)

, SK-Manship

SKMS

가

2000

가
가

(, , 가)

SKMS

, 2000

.

1979. 3.

-

-

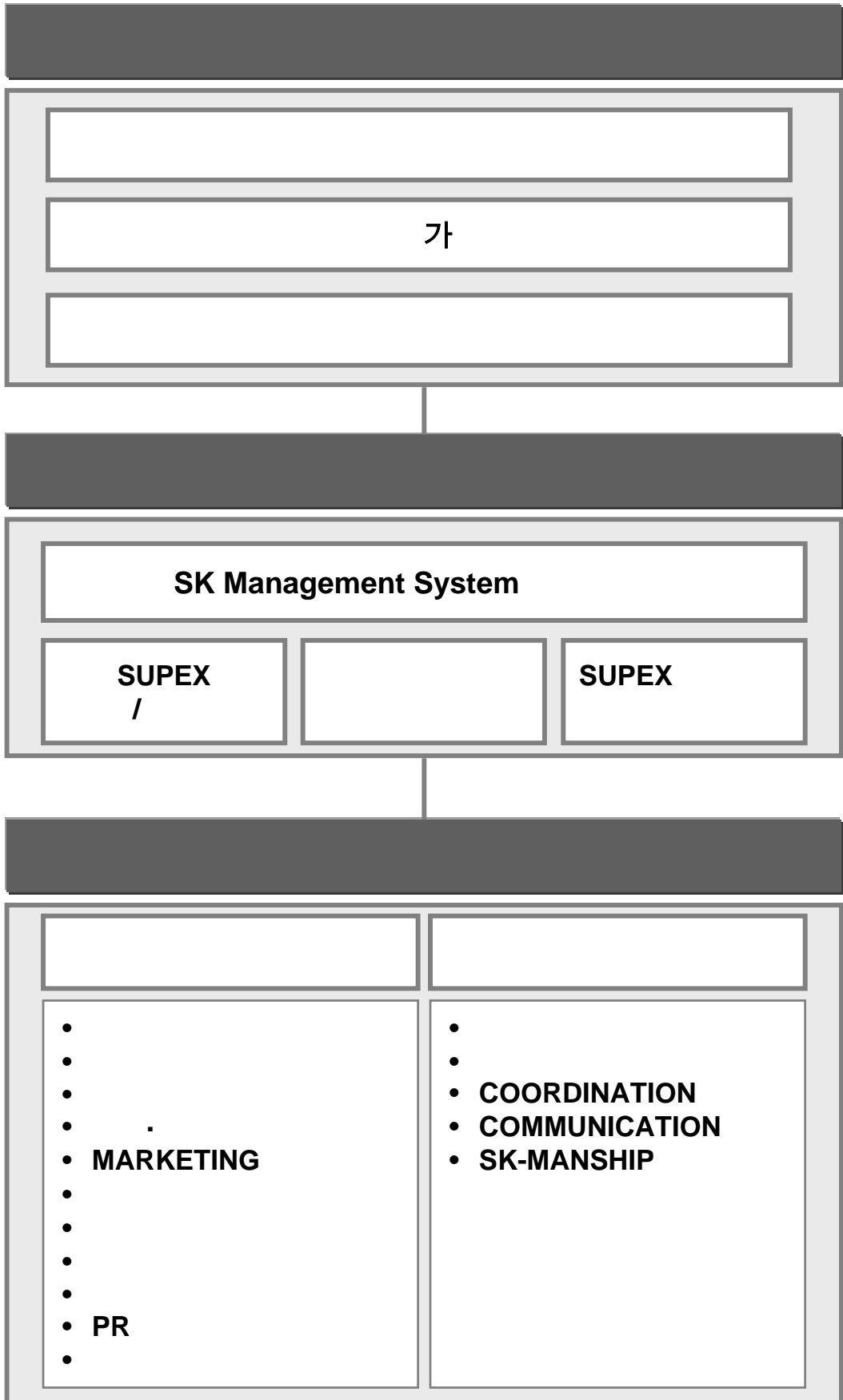

-
- 가
-



, ,

가
가

. .

가

.

,

가 가

가

,

,

.

,

.

가

.

- ' _____

SUPEX ' _____

가

,

Super Excellent

(SUPEX)

.

가_SUPEX 가

SUPEX

가

,
Engagement)

(Voluntarily)

(Willingly)

(Brain

()

가

SUPEX

SK

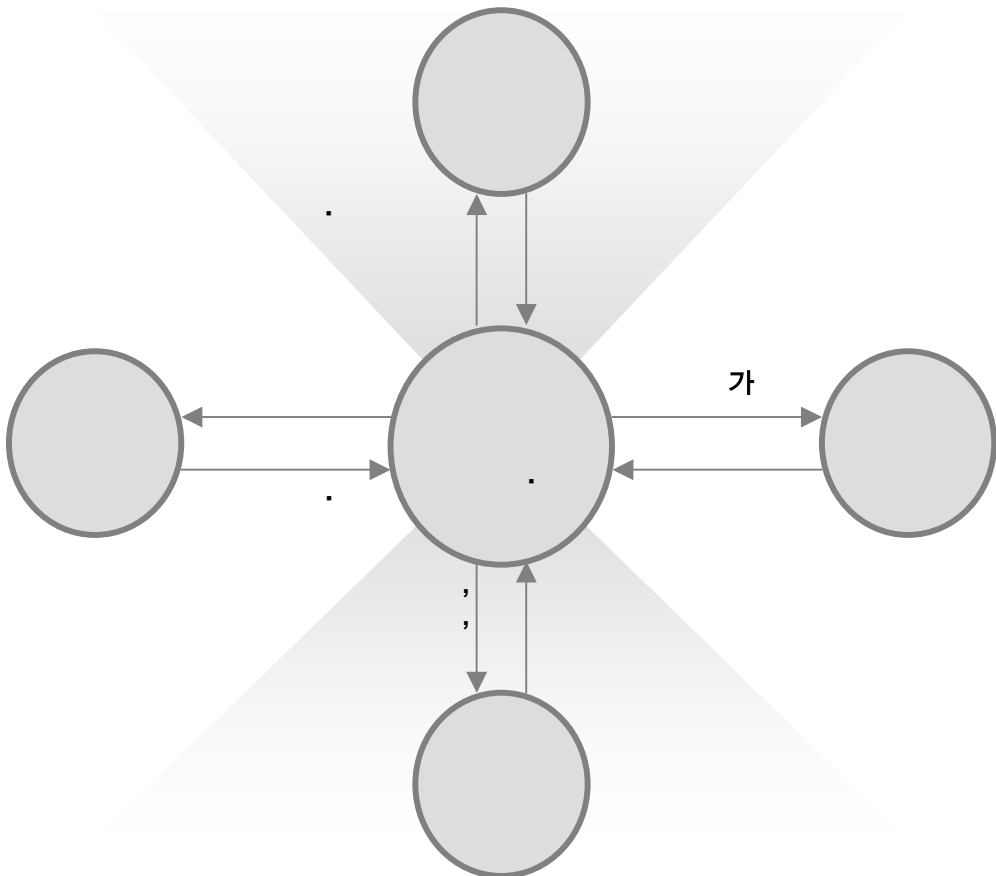

- SK Management System

- SUPEX /

-

- SUPEX

SK SUPEX ,

SUPEX 가 .

- SUPEX (SUPEX /)
- SUPEX ()
- SUPEX (SUPEX) SUPEX 가

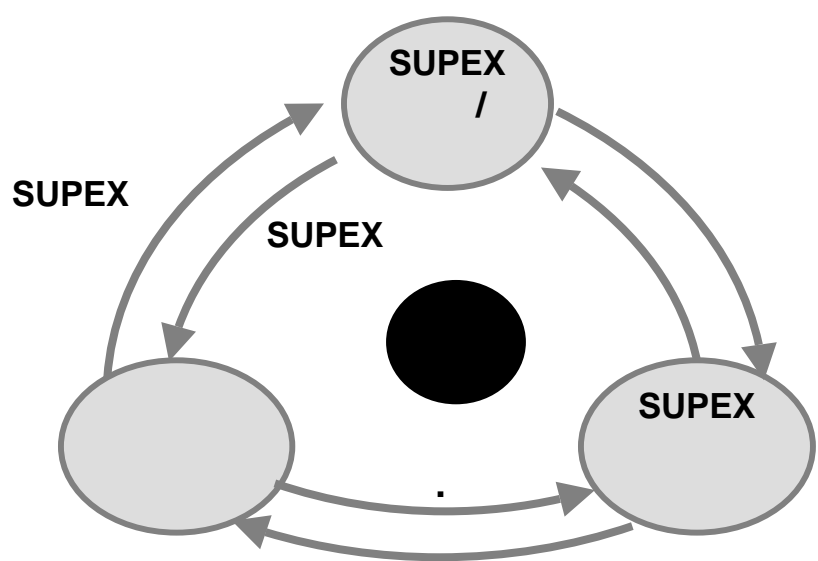

SK

SUPEX

가

•

가

가

•

가

SUPEX

•

가

, SUPEX

가

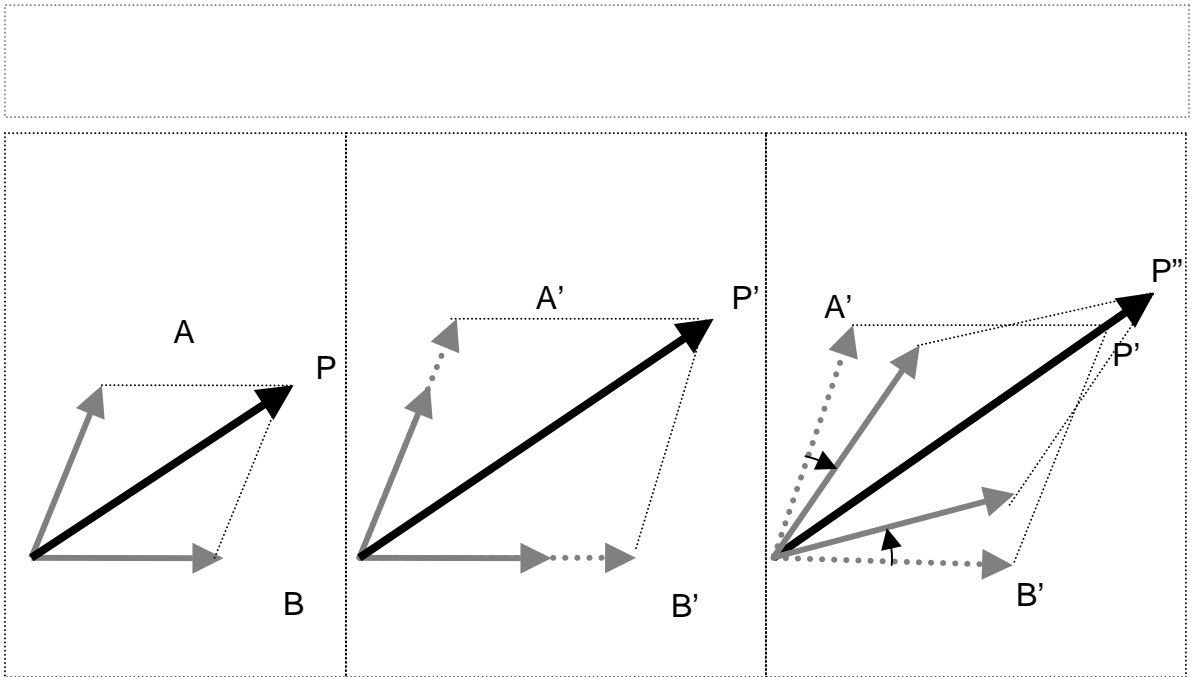

.

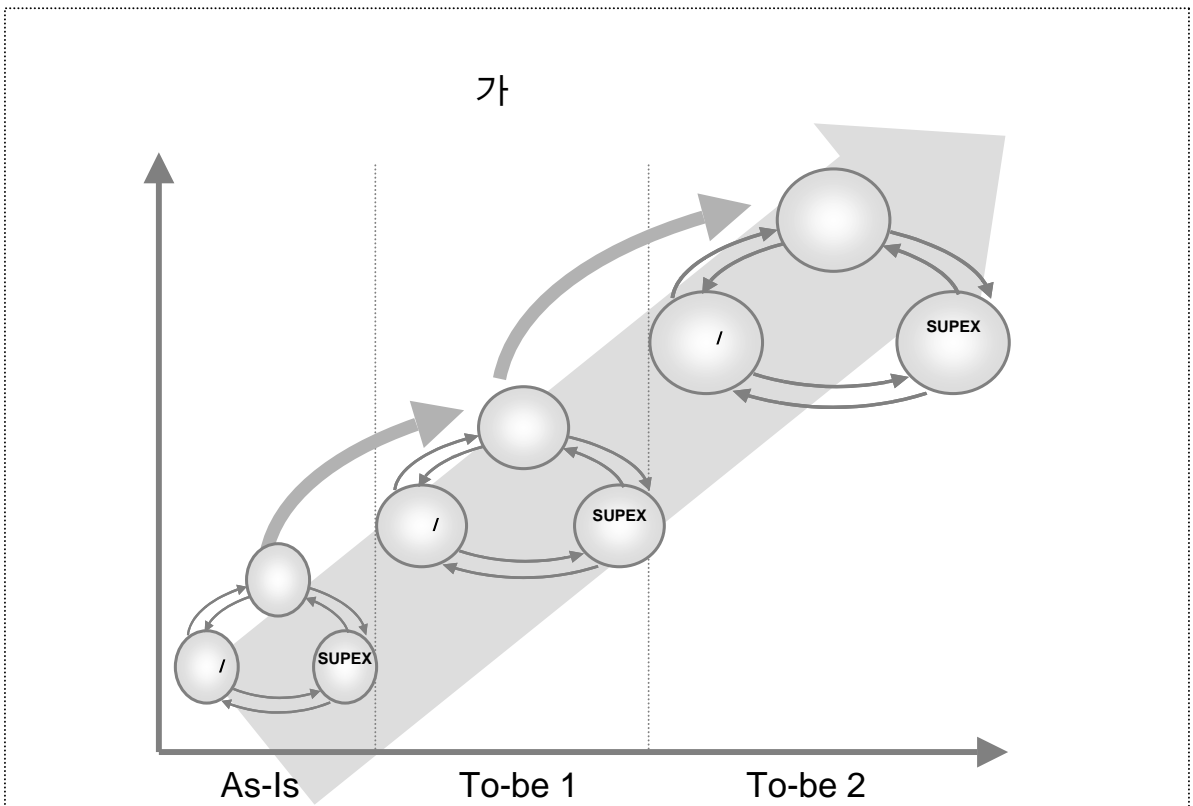

SUPEX Company
Company

가 Better

SUPEX Company

SUPEX Company

- 가 1 Market Share 가
- SUPEX Company
-

Better Company /

SUPEX Company

가

SUPEX Company

(Resource)

SUPEX

가

(Time) 가

(Better Company)

SUPEX Company

가

가

- Better Company , , SUPEX
- Super Excellent Challenging but Achievable(CbA)

- SUPEX To-be Model Better Company, SUPEX Better Company (KPI : Key Performance Indicator) 가 .
- To-be Model Better Company, SUPEX Better Company (KPI : Key Performance Indicator) 가 .

SUPEX

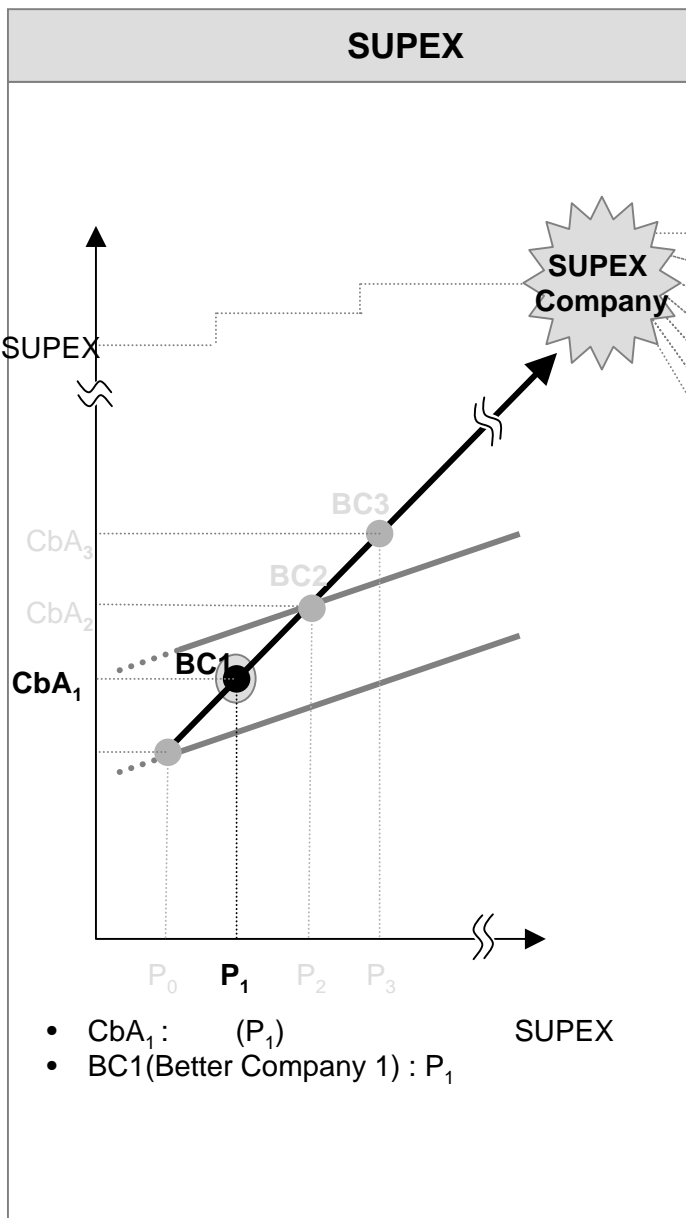

4~5 가 ,

Market Share	
.....	
.....	

Better Company

-

Market Share	
.....	
.....	

CbA

Better Company
Better Company

Better Company

Better Company

가

KPI

KPI

가

가

CbA

가

KPI

SUPEX

SUPEX

SUPEX

SUPEX
Company

Better
Company

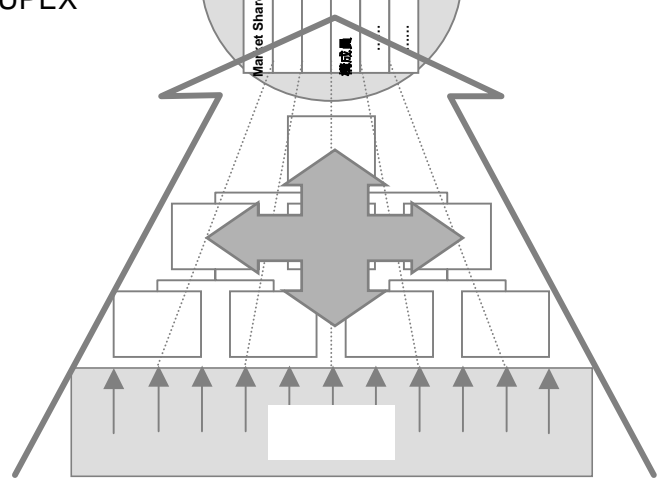
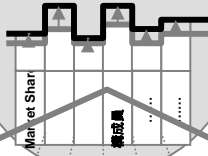



SK **SUPEX**

가 , .

SUPEX ,

가 ,

- SUPEX ,
Better Company ,
- 가 .
- 가 , 가 ,

SK SUPEX SUPEX

가 , .

- . 가 ,
- . 가 SKMS SUPEX .
- 가 , 가 Feedback .

SUPEX

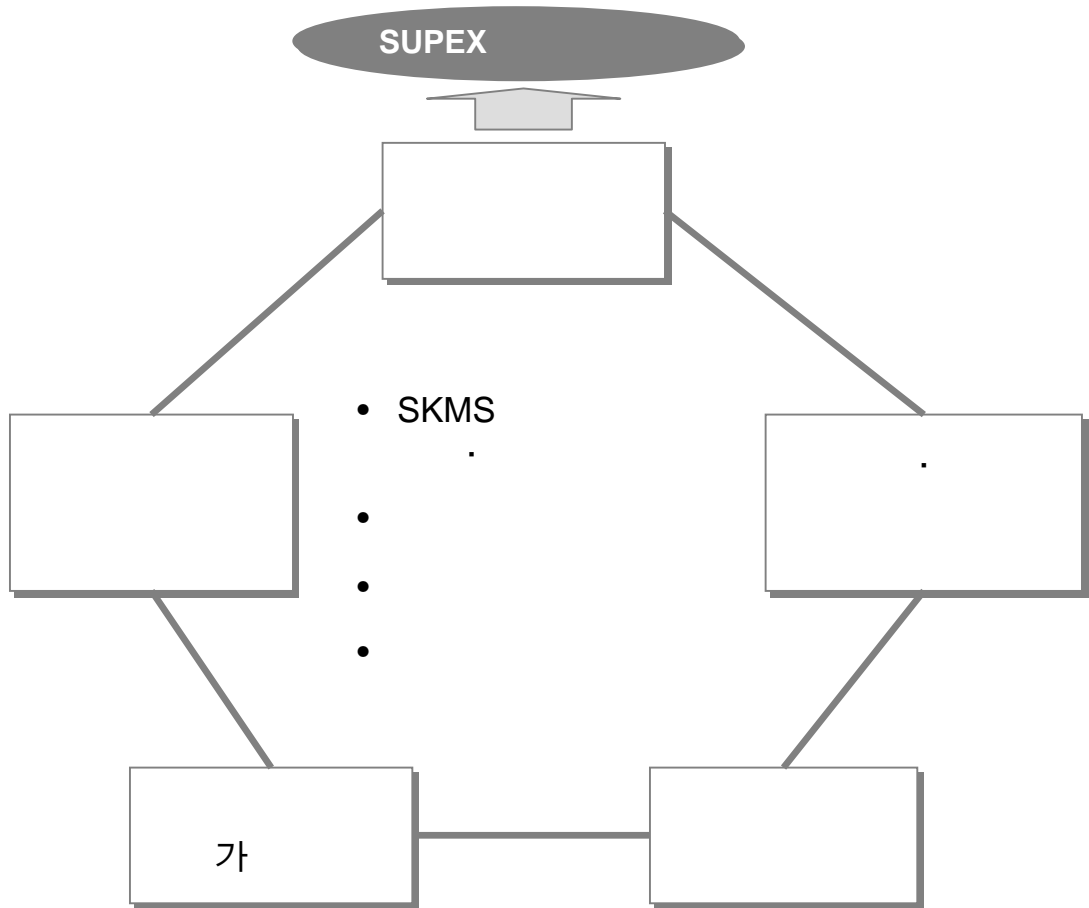

SUPEX

가

.

,

SUPEX

가

.

SUPEX

•

SUPEX

,

•

.

,

.

•

SUPEX

.

SUPEX

	(Work Management)	(People Management)
	<ul style="list-style-type: none"> • SUPEX • 11 / 	<ul style="list-style-type: none"> • • 5 /
	/	

SUPEX

- To-be Model
- To-be Model Better Co. SUPEX

- SUPEX

- SUPEX 가 .
- SUPEX Business Model . .
, 가 .
- , , SUPEX .
- SUPEX . .

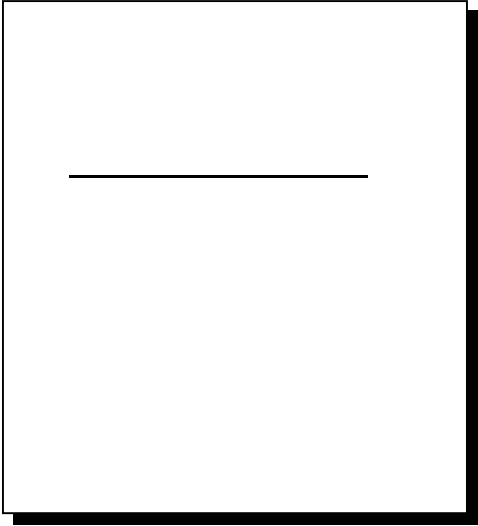

, SUPEX

가
가

가
가

'가,

가
가
.

가

.

,

가 .

가

,

가

.

가

가

,

.

_____ ()

.

.

,

,

,

,

.

,

,

SUPEX

.

가

.

()

$f(\quad , \quad , \quad , \quad) =$

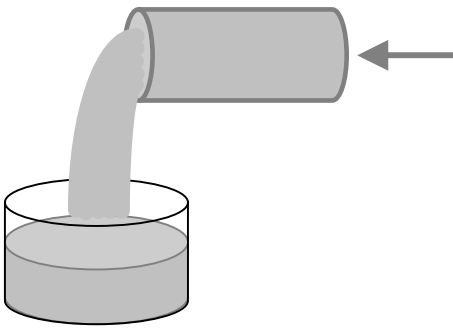

$f(\quad , \quad , \quad , \quad) =$

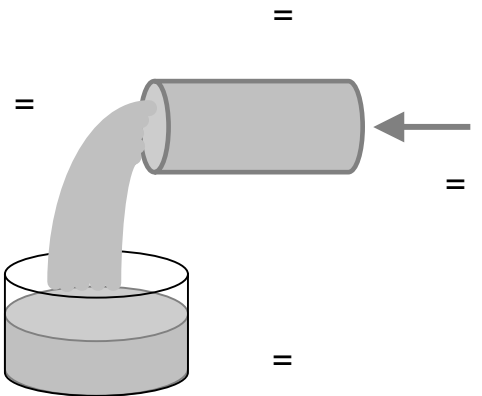

가

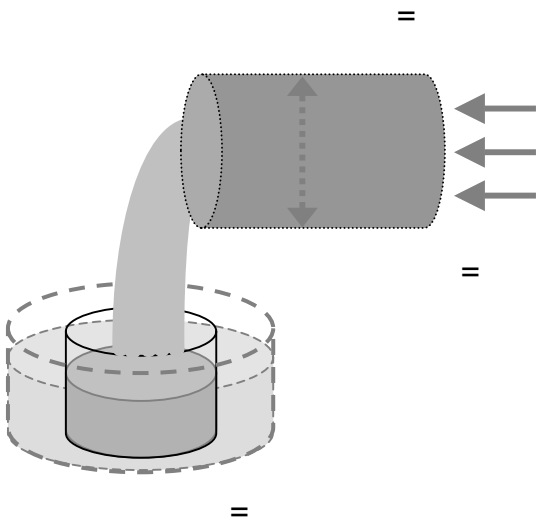

→
가

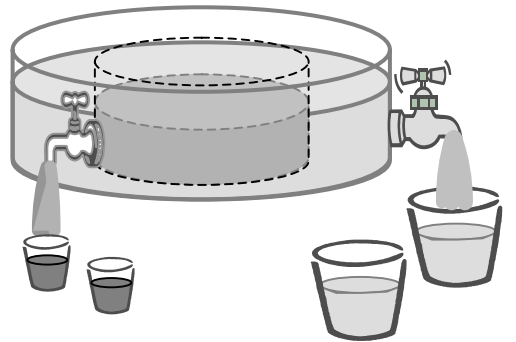

-
-
-
-
-
- **MARKETING**
-
-
-
-
-
- **PR**
-



1.

가.

Excellent

(Hardware)

To-be Model

To-be Model

To-be Model

Better Company

(Software)

가

Super

2.

가 , 가

가.

가

Super Excellent

가

()

가 . 가 Super Excellent 가

가

가 가 가

.

1. 가

Cooperation() Coordination()

Staff

.

가. Cooperation() ,

. 가

.

. Coordination() ,

.

. Staff , (Brain)

.

,

.

2. 가 가 가

(Span of Control)

.

가. (Span of Control) ,

가

.

.

.

,

,

가

.

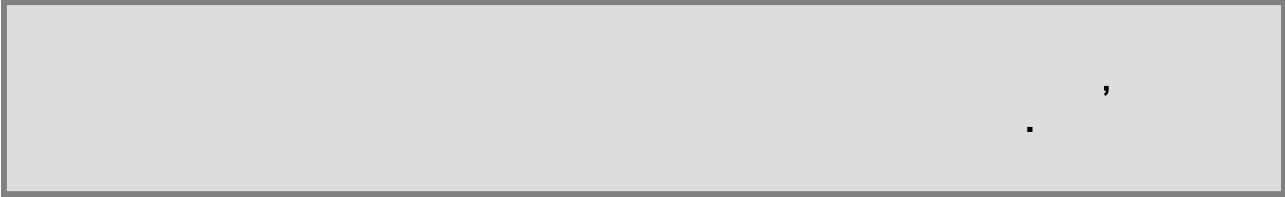

1. 가 , 가
 가. 가 ,
 1) . , ,
 2) . - =
 3) (÷ × 100) Marketing ,
 가 .
 4) , 가
 . 가 가
 .

2. 가 .
 가.
 1) . ,
 , 가 .
 2) (Pipeline)
 .
 1) (가) , ,
 , 가 .
 2) .

MARKETING

가

(Market Research)

(Merchandising) Promotion, (Sales), After Service 가

1. (Market Research)

가. 가 (Actual Market) 가 가 (Potential Market) 가

Segmentation) 가 (Target Market) (Market

2. (Merchandising) 가

가. 가 Coordination

3. Promotion

(Sales Promotion)

가.

가

, Rebate

. 가

Promotion

(Advertisement)

가

,

PR

, Catalogue,

,

,

,

4. (Sales)

가.

(Distribution Network)

5. After Service

가.

가

. After Service

Marketing

가

가

.

가
가

.

1.

0(Zero)

가.

.

.

2.

가.

(Steam,

가

)

.

가

3.

가

가.

()

()
Cost

.

Cost

4.

가.

Full Capacity()

.

.

가

,

,

.

1.

가

,

,

가,

,

.

,

가.

가

,

,

가

가

.

. Risk Hedging(

,

)

.

2.

,

가

,

,

.

3.

가

,

,

(

,

,

)

가

.

4.

SKMS

.

,

,

.

가

.

1. 가 , .
가. 가 ,
 , .
 . , , , ,
 . 가 .

2. 가 . 가 ,
가. 가 ,
 .

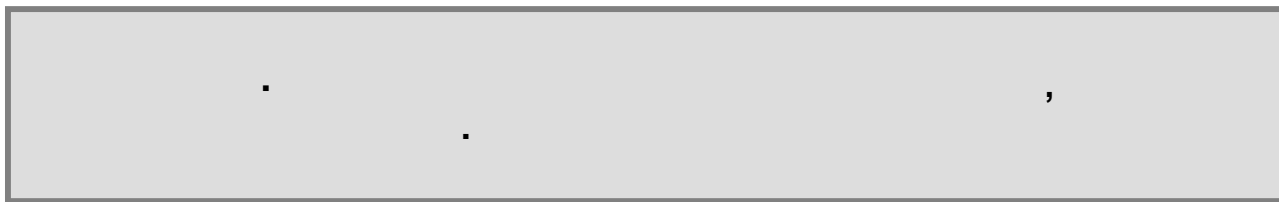

1.

, .

2.

가.

. .

. . , ,

,

.

3.

, ,

.

4.

. , ,

가. 가

.

. , 가 , 가 ,

,

.

. , .

.

. ,

.

. . 가 .

5.

가

,

.



1. (Potential) , (Invisible)
2. (Raw Information) , (Intelligence) Intelligence가
, Intelligence 가, , Intelligence가
3. (Knowledge) Intelligence
가 .
4. (Contemplation)
5. SUPEX
6. , , , ,
, , , ,
() .

-
- -
 - **COORDINATION**
 - **COMMUNICATION**
 - **SK-MANSHIP**

(Individual)

(Group)가

,

1.

가.

.

.

.

2.

가

가

3.

가

1.

가

2.

가

1. 가
.(Condition)

2. SK-Manship

3. ,

4. SK-Manship

5.

6.

7.

8.

9.



1. 가

2. 가.

3. Super Excellent

1. . ()

2. () , , .

3. 가 가

가. (Decentralization)가 (Centralization) 가

가

()

·
·
· 가 Can Meeting
·
· 가 (Power
Delegation)
·

COORDINATION

Cooperation Coordination

1. Cooperation() , 가
2. Coordination() ,
3. Cooperation Coordination
2 , 3 가
Coordination ,

Cooperation Coordination

Cooperation

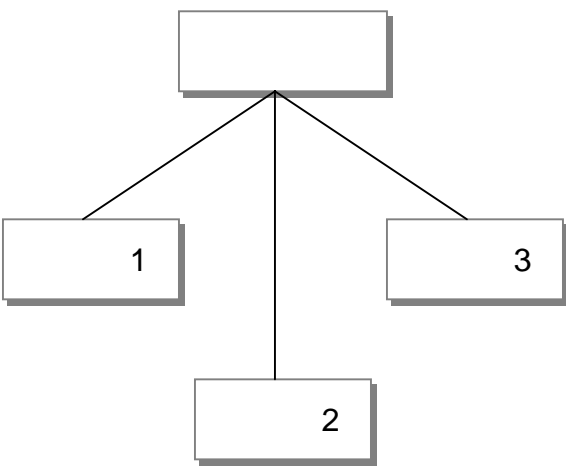

Coordination

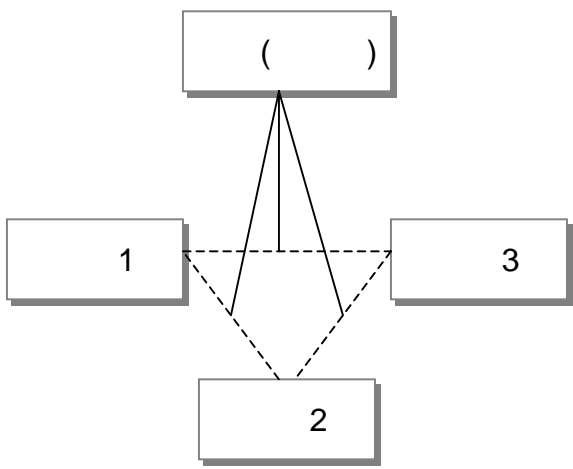

COORDINATION ()

Coordination

합 .
Coordination

Cooperation

.
Cooperation 가 Coordination .

COMMUNICATION

1.

2.

Meeting

3.

4.

가.

Feedback

Communication

1.

가

2. Communication

Communication

가

COMMUNICATION ()

1.

Can Meeting ,

2.

Feedback .

SK-MANSHIP

SK-MANSHIP

SK

가

SK

, 가

SKMS

. SKMS

SK

SK-Manship

가

가

SK

SK

SK

SKMS

SKMS가

SK

SK

가

가

가

가

SK

SK-Manship

SK

, ,가

, ,'

.

1. SK

Training 가

. SK

,

Training

Super Excellent

가.

가

.

.

가

가

2.

가

SKMS

, SKMS

.

3.

가.

2

(

Business

)

가 가

4.

가

가.

가

가

5. 가 , 가

가. 가

1)

2)

가

1. SK-Manship

SK-

Manship

2. SK-Manship

SK-Manship

3. SK-Manship

SK-Manship

SK-MANSHIP

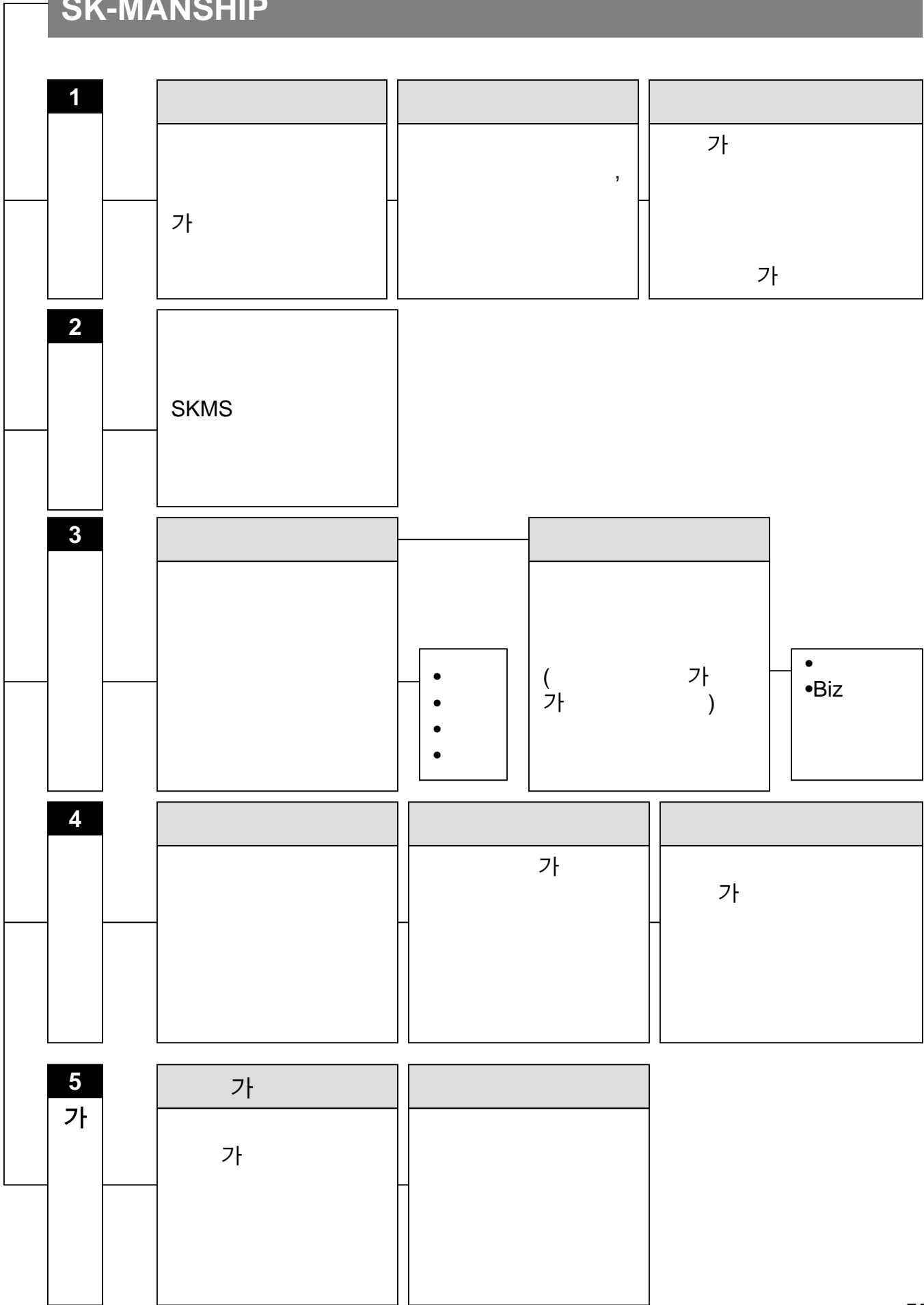

SUPEX

- **Super Excellent (SUPEX)**
- **5**
- **MPR/S/T**
- **Can Meeting**
- **SUPEX**

Super Excellent (SUPEX)

SUPEX , 「 Super Excellent 」

1. Super Excellent 가 .

가. Excellent Super

가 , 「 가 」

2. Super Excellent

(SUPEX) ,
(Time) 가 (Resource) Super Excellent
Company Better
Achievable (CbA) (Time) Challenging but
Super Excellent (Resource)

1. Location
2. KFS(Key Factor for Success)
- 3.
- 4.
- 5.

「 SK 가 「 5 」 .
 「 5 」 가 Can Meeting

가
 ,

1. Location
 가. , Location
 가 가 .

가 .

2. KFS
 가. KFS Key Factor for Success , Better Company
 가

3. , KFS SUPEX . SUPEX

4.

가.

,

가

.

.

가

.

5.

(Brain Engagement) 가

.

MPR/S/T

Marketing (M), (P), (R) 가
MPR Lead, Help, Check (MPR), Supporting MPR (Top
Management) MPR/S Lead, Help, Check (MPR/S/T)

1. Cooperation
가 Coordination

2. MPR/S/T Cooperation Coordination
(Boundary) Top
Communication 가
가

Can Meeting

가

.

1.

가 가
가 가

.

가

2.

.

가

Can Meeting

,

3. 가

가 , Can Meeting
가

4.

Can Meeting

5.

Can Meeting

가

SUPEX

SUPEX
MPR/S/T

「

5

」

KFS

SUPEX

1.

가

가

SK

SUPEX

가

2. MPR/S/T가

SUPEX

SUPEX

MPR/S/T

3.

가 가

「

5

」

SUPEX

4. Super Excellent

가

Can Meeting

5. SUPEX

가.

(Centralization)

Communication
(Decentralization)가

S, T

MPR/S/T
Coordination

SUPEX

M, P, R,

SKMS

'79. 3. 31.

'81. 3. 31.

1
 < >
 ()
 < >

'81. 10. 20.

2
 < >
 「 , . , , ,
 , 「 , , .
 , 「 가

'82. 3. 15.

3
 < >
 가
 < >

'84. 12. 20.

4
 < >
 가
 < >
 SKMS .

'88. 11. 1.

5
 < >
 「 , 「
 「
 <Coordination Coordination > Coordination

'89. 11. 1.

6
<Communication >
Communication ()
<Marketing >
Marketing

.
< >
가
< >

'90. 11. 1.

7
< >
, PR , ,
.

'95. 6. 13.

8
<SKMS >
SUPEX, 5 , MPR/S/T, SUPEX

'97. 3. 6.

9
< >

'98. 1. 1.

10
<CI >

'04. 10.

11
< >
, 가 ,

SK